

Dispensing



5-channel powder dispenser



Mixing



Single-channel centrifugal mixer



Calcination

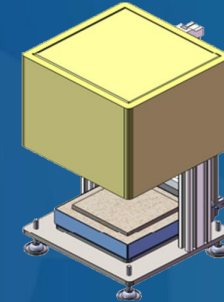

Bottom-loading muffle furnace 6"×6"×6"

Sintering

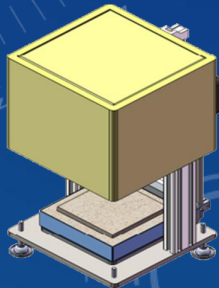

Bottom-loading muffle furnace 6"×6"×6"



Palletization

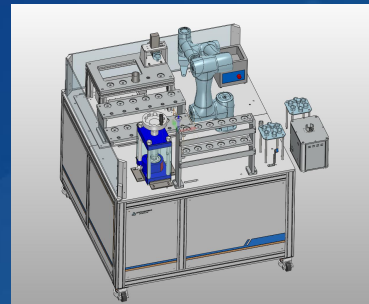

Automated Pallet Press



Crashing



Vibration Crusher



MTI Corporation

860 S. 19th St., Richmond, CA, 94804
Since 1994 www.mtixtl.com (510) 525-3070

Layouts

Estimated Dimensions (L x W x H):
2500 x 2500 x 1800 mm

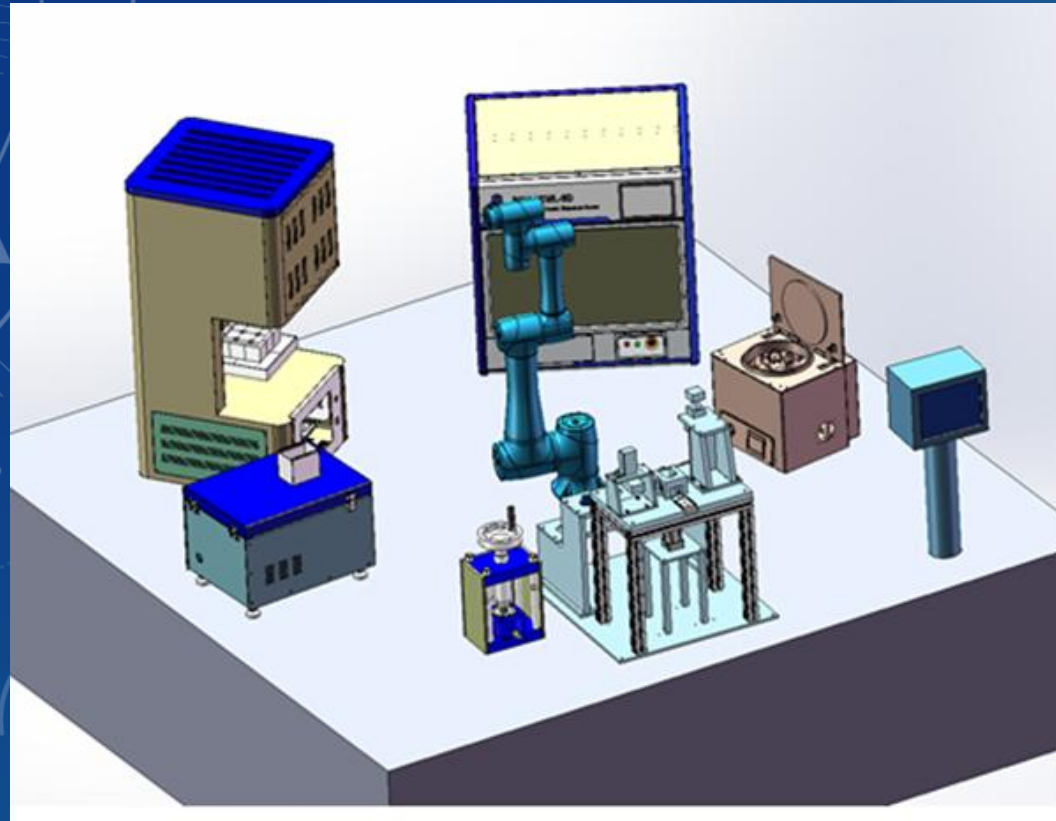

MTI Corporation

860 S. 19th St., Richmond, CA, 94804
Since 1994 www.mtixtl.com (510) 525-3070

Operation Video



MTI Corporation

860 S. 19th St., Richmond, CA, 94804

Since 1994 www.mtixtl.com (510) 525-3070

Equipment List

Part Number		Product Name	Quantity
1	MSK-HTML-SD	5-Channel Solid Powder Dispenser with Precision Scale for High Throughput Preparation	1
2	MSK-PCV-310AR	Single Container Planetary Centrifugal Mixer	1
3	MSK-VGM-50	Compact Vertical Impact Grinder and Mill	1
4	TBD	12-channel Automated Pallet Press	1
5	KSL-1200X-BSA	1200°C Compact Automatic Bottom Loading Furnace	2 or more
6	TBD	Robotic Arm, Integrated Software Control, touchscreen, and Monitors	1
7	TBD	Surveillance Cameras for Remote Monitoring	1 set
		Total	About 500K

16-channel Automated Coin Cell Assembling System for Individual Composition

Electrolyte can be prepared by the
combination of the dispensers below



5-channel liquid dispenser

Mixing



16-channel Automatic Assembling Machine



MTI Corporation

860 S. 19th St., Richmond, CA, 94804

Since 1994 www.mtixtl.com (510) 525-3070

Equipment List

Part Number	Product Name	Quantity	MSRP	Discount	Cost	
1	MSK-HTML-LD	Compact Liquid Distributing System with 6-Channel Metering Pumps & Stream Dispensers	1	\$70k	30%	\$49K
2	TBD	Benchtop Vortex Mixer	1			
3	MSK-110-A16	16 Channels Automatic Assembling Machine for All Types of Coin Cells	1	\$85k		\$59.5k



MTI Corporation

860 S. 19th St., Richmond, CA, 94804
 Since 1994 www.mtixtl.com (510) 525-3070

Automated Coil Cell Sample Preparation Product Process



Raw Material
Dispensing



Centrifugal
Mix



Automated
Tape Casting



Automated
Calendaring



Die Cutting



Coin Cell
Assembling



Cell Analyzing

1. Lab-scale automated coin cell research line from chemical dispensing to cell analyzing.
2. Fully automation; Autonomous operation 24x7.
3. Accommodate either cathode, anode, or electrolyte materials for education and research purposes.
4. Operations in dry room



Since 1994

MTI Corporation

860 S. 19th St., Richmond, CA, 94804
www.mtixtl.com (510) 525-3070

Compact Detached Dry Room (10'x10', 100 sqft)



Dew Point



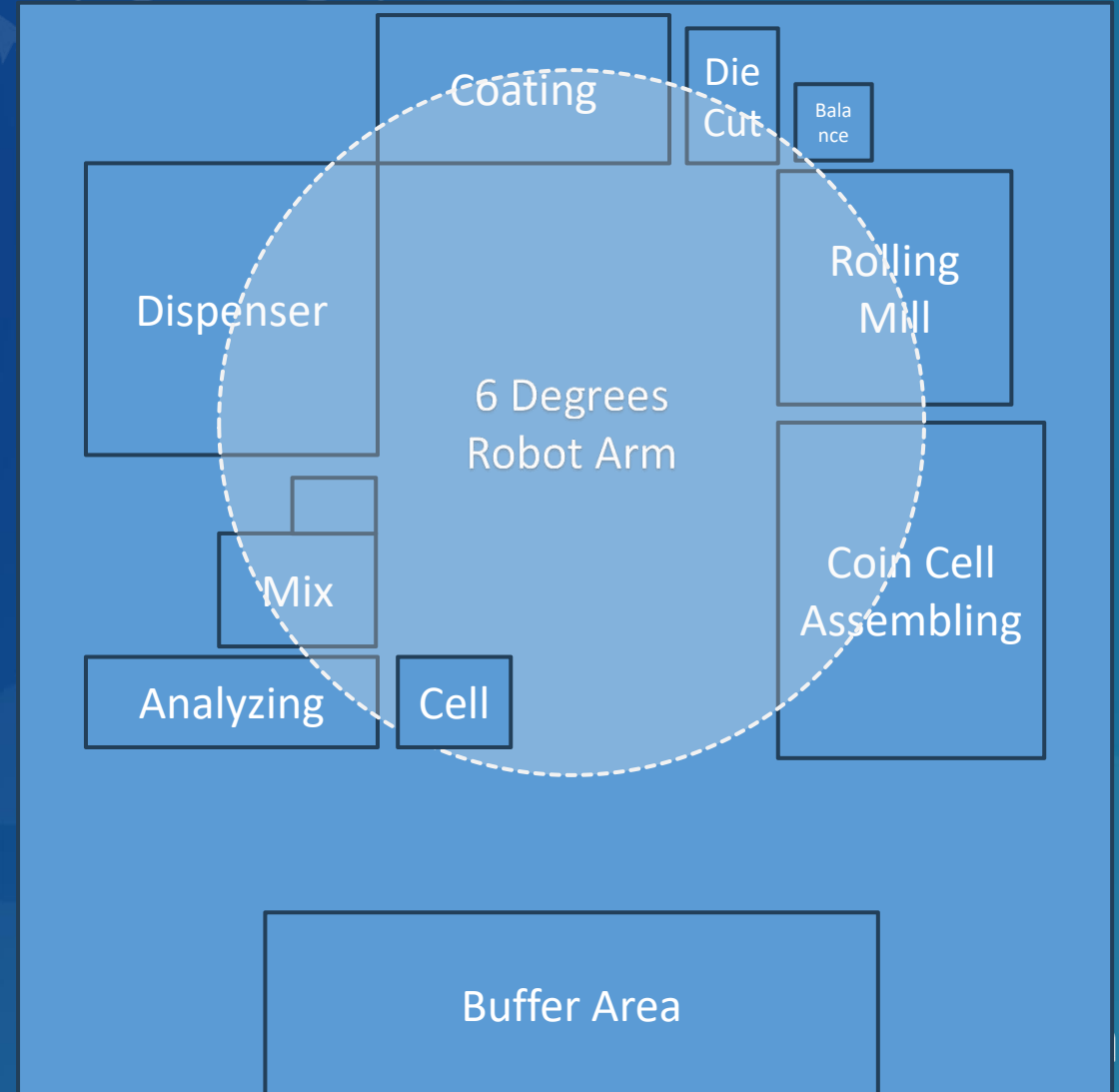

-40°C with two operators

Operation Area

2,920 mm L x 2,920 mm W x
2,100 mm H

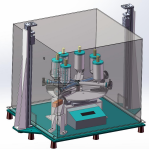

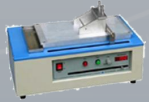
Equipment List



Part#	Product Name	Quantity	MSRP	Discount	Price
1	 5-channel Dispensing system (2 solids, 3 liquids)	1			\$52K
2	 Single channel Centrifugal Mixer MSK-PCE-V2150 (30 ml each)	1			\$31k
3	 Automated vial sealer to cap and uncap the vials	1			\$5k
4	 Automated Coating System Coating area 50 mm x 100 mm with IR drying, ultrasonic cleaning MSK-AFA-III-AM	1			\$70k
5	 Automated Calendaring System to calendar foils back and forth MSK-HRP-05-AM	1			\$65k



MTI Corporation

860 S. 19th St., Richmond, CA, 94804
 Since 1994 www.mtixtl.com (510) 525-3070

Equipment List

Part#	Product Name	Quantity	MSRP	Discount	Unit Price
6	 Pneumatic Die Cutter MSK-180-SP	1			\$20K
7	 Automated Coin Cell Assembling System MSK-110-A16	1			\$70k
8	 8-channel Pneumatic Coin Cell Fixture	2			\$35k
9	 8-channel Battery Analyer (0.02 – 10 mA, 5 V) BST8-MA	2			\$5k
10	 Global Robot Arm With 6 degrees of freedom	1			\$50k



MTI Corporation

860 S. 19th St., Richmond, CA, 94804
 Since 1994 www.mtixtl.com (510) 525-3070

Equipment List

Part#	Product Name	Quantity	MSRP	Discount	Unit Price
11	 Detached Dry Room (10'x10') MSK-ADR-1500EP40	1			\$200K
12	Automation Integration	1			\$300k
13	On-site Installation and Commissioning	1			\$70k
	Total				\$970k



Since 1994

MTI Corporation

860 S. 19th St., Richmond, CA, 94804

www.mtixtl.com (510) 525-3070